



LC 144 VF

HIGH SPEED MODEM for

- • **Data Transmission**
- • **Fax**
- • **Speech Messages**

User Manual

CREATIX Polymedia GmbH
Fasanerieweg 15
66121 Saarbrücken

This handbook is protected by copyright. It must not be copied, reproduced, translated or transmitted in electronic media, in whole or in part.

Accuracy of the information is not guaranteed.

Any mention in this handbook of products made by other manufacturers is for information purposes only and represents no misuse of trademarks.

Table of contents

Chapter 1 INTRODUCTION 1-1

- What is a Modem ? 1-1
- About this Modem 1-1
- Special Features 1-2
- General Description 1-2
- Installation Instructions 1-2
- Basic Adjustments 1-3

Chapter 2 AT COMMANDS: DATA MODEM 2-1

- Guidelines for Using AT Commands 2-1
- AT - Attention Code 2-4
- The ESC Sequence 2-4
- A - Answer Mode 2-4
- A/ - Repeat Last Command Line 2-5
- B - BELL/CCITT Standard 2-5
- D - Automatic Dialling and Dialling Parameters 2-5
- E - Echo Function 2-6
- F - Determining Type of Modulation and Speed 2-6
- H - Switch Hook Check (Replace Handset) 2-7
- I - Firmware Information 2-7
- L - Volume Level of Connected Loudspeaker 2-7
- M - Switching the Loudspeaker On and Off 2-7
- N - Recognizing Type of Modulation 2-7
- O - Return to On-Line Operation 2-8
- P - Selecting Pulse Dialling 2-8
- Q - Modem Messages On / Off 2-8
- S - Reading and Modifying Registers: 2-8
- T - Selecting Tone Dialling 2-8
- V - Verbal or Numeric Modem Messages 2-8
- W - Controlling Connect Messages 2-8
- X - Extended Connect Messages; Making Connections 2-9
- Y - Long Space Disconnect 2-9

Z – Reset/Load a Stored Profile 2-10
&C – M5 Control Line 2-10
&F – Loading the Factory Settings 2-10
&G – Guard Tone 2-11
&K – Flow Check 2-11
&M – Asynchronous Dialling / Synchronous Data Transmission 2-11
&Q – Synchronous / Asynchronous 2-11
&R – Control Lines S2 and M2 2-12
&S – Control Line M1 (107/DSR) 2-12
&T – Modem Test Functions 2-12
&V – Displaying the Current Configuration 2-13
&W – Storing a set Profile 2-13
&X – Setting the Clock Signal in Synchronous Mode 2-14
&Y – Selecting a Start Configuration 2-14
&Z – Telephone Number Storage 2-14
\A – Maximum MNP Block Size 2-14
\B – Sending a Break Signal 2-14
\F – Displaying the Telephone Number Store 2-15
\G – Modem/Modem Flow Check 2-15
\J – Baud rate Adjustment via the Computer 2-15
\K – Type of Break Control 2-16
\L – Determining Block/Stream Mode with MNP 2-16
\N – Data Transmission Mode 2-16
\S – Displaying the Configuration 2-17
\W – Split Speed Operation 2-17
-K – Extended MNP Operation 2-17
%C – Authorise Data Compression 2-18
%E – Automatic Retrain 2-18
%F – 75Tx/1200Rx or 1200Tx/75Rx in V.23 Mode 2-18
*H – Handshake Speed with MNP 10 Modem: 2-18
*C – Password for Remote Configuration 2-18
*R – Remote Configuration 2-19
*E – End Remote Configuration 2-19
*P – Password for Automatic Callback 2-19
*L – Displaying Callback Numbers 2-20

Chapter 3 DIALLING WITH V.25.Bis 3-1

Chapter 4 MODEM MESSAGES 4-1

Chapter 5 S-REGISTERS 5-1

S0 – Number of Ring Characters before Modem engages 5-2

S1 – Ring Character Counter 5-2

S2 – Esc Sequence Character 5-2

S3 – Carriage Return Character 5-2

S4 – Line Feed Character 5-2

S5 – Backspace Character 5-3

S6 – Waiting Time for Dialling Tone 5-3

S7 – Waiting for Carrier Signal 5-3

S8 – Pause Time after Comma 5-3

S9 – Answer Time after Carrier Recognition 5-3

S10 – Delay between Carrier Loss and Hanging Up 5-4

S12 – Guard Time for Esc Sequence 5-4

S14 – General Options 5-4

S16 – Modem Test Options 5-5

S18 – Test Timer 5-5

S19 – Autosync Register 5-6

S20 – HDLC Address/BSC Synchronous Character 5-6

S21 – V.24/General Options 5-6

S22 – Loudspeaker/Authorised Modem Messages 5-7

S23 – General Options 5-7

S24 – Current Saving Switch 5-8

S25 – DTR Delay Time 5-8

S26 – Delay RTS to CTS 5-8

S27 – General Options 5-8

S28 – General Options 5-9

S29 – Flash Dial Modifier Time 5-9

S30 – Inactivity Timer 5-9

S31 – General Options 5-10

S32 – XON Character 5-10

S33 – XOFF Character 5-10

S36 – Fallback on V.42 Connection Set-up 5-10

- S37 – Speed on the Telephone Line 5-11
- S38 – Delay before Hanging Up 5-11
- S39 – Flow Control 5-11
- S40 – General Options 5-12
- S41 – General Options 5-12
- S46 – Authorising a Data Compression 5-13
- S48 – Directing the V.42 Handshake 5-13
- S80 – Soft Switches 5-13
- S82 – Treating the Break Signal 5-13
- S86 – Error Codes for NO CARRIER Messages 5-14
- S95 – Extended Connection Messages 5-14

TECHNICAL INFORMATION A-1

Digital Interfaces A-1

Audio Jack A-1

LED Indicators A-2

GLOSSARY A-2

CCITT RECOMMENDATIONS A-3

Technical Specifications A-4

The Data Modem you have purchased represents the latest state of the art in data communication; its comprehensive facilities provide all you will need for professional data transfer purposes.

In data modem mode, you can achieve active transfer speeds of up to 57 600 bps and up to 14 400 bps in fax mode.

This handbook, together with the descriptive information provided with your communications software, gives all the information you need to install and operate the equipment.

What is a Modem?

The word “Modem” is derived from the terms “MOD-ulator” and “DE-modulator”. Putting it more simply, it is a device which modulates digital information into an analogue carrier signal (tones) and demodulates the carrier signals which it receives, changing them back into digital data. This permits the transmission of data along wires, between data terminal equipment (computers, terminals, etc...).

About this Modem

This modem operates as a full duplex, voice-band modem, where signal transmissions are made in both directions simultaneously and the analogue signals which are transmitted are in the voice-band of the telephone network - between 300 and 3000 Hz.

Data transmission between modem and terminal unit is in serial form - in other words, the individual data bits are sent, one after another, along a single transmission or receiving line. At this stage, a word of explanation regarding synchronous and asynchronous data transmission. In the synchronous mode, additional synchronisation signals are required, to synchronize the transmission and reception signals. In the asynchronous mode synchronisation is by means of “start-bits” and “stop-bits” which mark the beginning and end of each data word. The modem can dial by itself and also react automatically to incoming calls. The information it needs in order to dial a telephone number, together with the various configuration commands, are provided by the respective data terminal equipment via the same serial interface which is used to send the data. In this mode, the system operates with the so-called “AT” command set or to V.25bis.

Special Features

- Fax Transmission and Reception at up to 14 400 bps
- Automatic recall of Stored Telephone Numbers, with
- Password Protection
- Remote Configuration
- Number Storage for 20 Telephone Numbers
- Voice Mode for Onward Transfer of Voice
- Information (Option)
- Compression/Decompression of digitized speech

General Description

- Synchronous or Asynchronous
- Auto-protocol: the Modem adjusts automatically to all Full Duplex Transmission Protocols and Speeds
- MNP 5 and V.42bis Data Compression and Error Correction
- MNP 10; specially useful in association with Radio Telephones
- Max. 57 600 bps Active Transmission Rate (V.32bis with V.42bis)
- Automatic Baud Rate Recognition at all Speeds up to 57 600 bps in Hayes Mode
- Automatic Dialling with Hayes AT Command Set or with V.25bis
- Automatic Recall with Password Protection
- Remote Configuration is possible over Telephone Line

Installation Instructions

1. Use the interface cable supplied to connect the modem to a free COM interface on the computer
 2. Use the telephone cable supplied to connect the modem to a Telephone jack
 3. Use the mains cable supplied to connect the modem to a power socket (220-240 VAC)
 4. When the "POWER" LED is lit, the modem is ready for operation and will provide data communication, using the factory settings which have been installed
 5. Configure the modem with the communications software or fax software to meet your requirements
- ⇒ *Voice Mode is available only with the appropriate Accessory Pack*

Basic Adjustments

To make it easier for you to use your modem, two basic settings have been made at the factory, which are suitable for the vast majority of connection systems. These settings can be activated with the “&F” command. In the fax mode or voice mode, the relevant software will carry out control of modem settings for you.

- for **BTX Operation (Datex-J with 2400 bps)**, select **AT&F1** in the software as the initialisation sequence
- For general **Remote Data Transmissions** select **AT&F0**. In this condition, the modem will attempt to create an error-corrected connection with data compression, depending on the capability of the other party

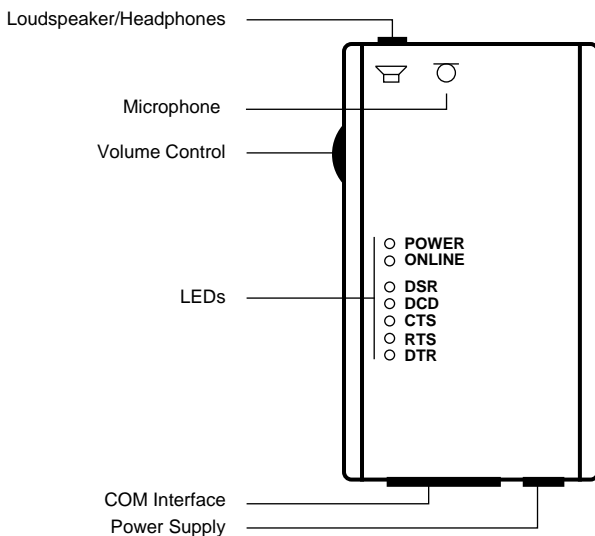

What the LED Indicators mean:

- **POWER** Modem is ready for operation
- **ONLINE** Modem is switched to the transmission line
- **DSR** Answer tone is present
- **DCD** Modem has recognized the carrier tone from the remote modem
- **CTS** Modem is ready to transmit
- **RTS** Transmission request is present
- **DTR** Computer is ready for operation

⇒ *Ensure that the correct COM interface is used for the software employed !*

Guidelines for Using AT Commands

The modem is programmed with AT commands from the data terminal equipment (computer, PC or terminal) and thus also receives instructions to cover automatic dialling. The communications or fax software (Voice Software as an option) will carry out most of these operations for you, so that in general circumstances you do not need to have a detailed understanding of the commands which are described below.

The modem must be in Command mode before it can accept commands. In this condition, all the characters sent from the computer are interpreted as commands and, where appropriate, confirmed by a modem message on the screen. When a connection is set up to a remote modem, the modem will switch to data mode and transfer all the characters it receives to the other party.

The modem can be switched from an existing connection, back into the command mode, by using the **Esc Sequence** (+++), **without** breaking off the connection to the remote modem. In this status, any commands which are entered will not be transferred to the remote modem.

The modem is activated by AT commands, the subsequent value of which will modify the form of the command. Modem messages provide information on the form of the commands.

In the Hayes Command Set, commands are entered by the character sequence **AT (at)** and can also be entered as a list of commands with or without spaces between the individual commands. The “Backspace” key is used for deleting. Commands can be entered in upper-case or lower-case. In the command mode, the modem automatically recognizes data frames and data speed.

◇ *AT commands can be transferred to the modem at the following data speeds: 57600, 38400, 19200, 14400, 9600, 4800, 2400, 1200, 600 and 300 bps*

Examples of Command Syntax:

ATX1<CR>

ATQ0<CR>

ATDP12345<CR>

Individual commands ending with the <CR> Enter key, can be entered in a different manner with the same effect, by inserting as many spaces as you need, to make the command easier to visualise

ATX1Q0DP12345<CR> or:

AT X1 Q0 DP 12345<CR>

Table 1**Modem Commands**

Standard Commands	
ATA	Answer mode: Modem monitors telephone line
A/	Repeat last command line; entered without "AT"
ATB	Switching between BELL/CCITT Standards at 300 or 1200 bps
ATD	Enter automatic dialling
ATE	Controlling repeat of modem commands on screen
ATF	Determine type of modulation and speed
ATH	Break off an existing connection
ATI	Information on Modem product code
ATL	Loudspeaker volume control
ATM	Switch on loudspeaker
ATO	Return to Online-mode after entering Esc sequence
ATP	Select Pulse dialling
ATQ	Controlling modem messages
ATS	Read and modify modem register(s)
ATT	Select Tone dialling
ATV	Modem message format (verbal or numeric)
ATW	Directing speed messages
ATX	Modem function during dialling; modem messages
ATY	Long Space Disconnect
ATZ	Modem Reset and Load one of the stored modem profiles
+++	Escape Sequence to return temporarily to Command mode
AT&C	Controlling M5 (DCD) Signal at the serial interface
AT&F	Load the factory setting
AT&G	Switch on a Guard Tone
AT&K	Flow Check
AT&M	Synchronous data transmission with asynchronous dialling
AT&Q	Authorised types of connection
AT&R	Controlling M2 (CTS) and S2 (RTS) Signal at the serial interface
AT&S	Controlling M1 (DSR) Signal at the serial interface
AT&T	Modem test functions
AT&V	Displaying current configuration
AT&W	Storing Modem settings
AT&X	Directing the Clock Signal
AT&Y	Selecting the configuration which will be active after modem start
AT&Z	Storing telephone numbers

Extended MNP- and V.42bis-Commands	
AT\A	Determining Data Block Size with MNP operation
AT\B	Sending a Break signal to the remote modem
AT\F	Display stored telephone numbers
AT\G	Modem-modem flow check (XON/XOFF)
AT\J	Adjusting computer/modem speed to the modem/modem speed
AT\K	Effects of the Break Signal
AT\L	MNP Block/Stream mode
AT\N	Switching between Direct, Normal and MNP modes
AT\S	Displaying current modem configuration on screen
AT\W	Authorise V.23 operation
AT\U	Accept an MNP connection in a Normal connection
AT\V	Information content of MNP connection messages
AT\X	Transfer XON/XOFF control characters to the remote modem
AT\Y	Switch to error-free connection from Normal connection
AT\Z	Switch to Normal connection from an error-free connection
AT%<i>C</i>	Controlling Error correction and Data compression
AT%<i>E</i>	Authorise data compression
AT%<i>F</i>	Dialling 75Tx/1200Rx or 1200Tx/75Rx
Other Commands	
AT*<i>C</i>	Storing password for remote configuration
AT*<i>E</i>	Ending remote configuration
AT*<i>H</i>	Handshake speed between MNP 10 modems
AT*<i>L</i>	Displaying Directory for callbacks protected by password
AT*<i>P</i>	Storing passwords for automatic callback
AT*<i>R</i>	Interrogating for remote configuration
AT-<i>K</i>	Authorising extended MNP Class 10
V.25bis Commands	
CIC	Modem goes in Answer mode on to line
CRI	Dialling command with optional identification
CRN	Dialling command
CRS	Dialling a stored dialling string
DIC	Ignore incoming call
PRI	Store programme identification
PRN	Store dialling strings
RLN	Displaying stored telephone numbers (dialling strings)

AT - Attention Code

The AT (Attention) Code, which introduces each command line, can be entered in upper-case or lower-case characters.

Several commands (separated by spaces if desired) can be positioned one after another, in one line. A command line must end with the ASCII character which is stored in the S3 or S4 Register (or with both together). The standard value for S3 is Carriage Return (<CR>=13 decimal) and Line Feed (<LF>=10 decimal) for S4.

A command line without <CR>,<LF> will remain in the command buffer until <CR>,<LF> is entered, or until the action is broken off with <Cntrl-X>. Once <CR>,<LF> has been received, the modem carries out the commands following the **AT** and answers with an appropriate modem message.

The maximum length of a command line is 40 characters. If the capacity of the command buffer is exceeded, the modem issues an Error message.

⇒ *The AT code enables the modem to recognize the speed, parity and character-length of the communication programme*

The ESC Sequence

If the modem has established a data connection, you can enter more commands at any time, without breaking off the connection. This is achieved by sending three ASCII characters (S2 Register) from the computer to the modem. The standard setting is the “+” character. In order for this to be interpreted as the ESC sequence, certain time limits must be observed in entering the plus-characters. Before the first and after the last character, a Guard time is required (the standard is 1 second) and the individual characters must not be separated from each other by longer than this time period.

A - Answer Mode

When the A command is entered, the modem switches to the “Off-Hook” condition in the Answer mode and takes over control of the telephone line connected. In this way, the modem transmits in the upper frequency band (upper channel)

If further commands are entered after the **A** command before a connection has been made, the modem interrupts the establishment of a connection, switches to command mode and issues a NO CARRIER message.

If no carrier is received from the remote station after the waiting time which is set in the S7 Register, the modem responds with a NO CARRIER message and returns to command mode. If the modem does receive the carrier signal, it issues a CONNECT message and switches to Data mode.

⇒ *If the handset is not replaced after the data transmission has been completed, the connection remains made and you will continue to pay for this !*

A/ - Repeat Last Command Line

The A/ command causes the modem to repeat the command line which is stored in the command buffer, e.g. it will dial again, if the line is busy. This command is entered without AT and no reply is issued.

- ☞ *A command line remains until the modem receives a new command. The data format should not be modified in the meantime.*

B - BELL/CCITT Standard

The B command permits change-over between CCITT and Bell standards at 300 or 1200 bps. At 300 bps, this command will select between Bell 103 and CCITT V.21, while at 1200 bps it will select between Bell 212A and CCITT V.22.

ATB0 CCITT V.22, V.21 (factory setting)

ATB1 Bell 212A, Bell 103

- ☞ *The B command refers only to connections at 300 or 1200 bps. All other speeds use the CCITT standard.*

D - Automatic Dialling and Dialling Parameters

The D command instructs the modem to go on-line and to dial. If this command is entered without parameters, the modem will go on-line in Originate mode. The following characters are authorised in the dialling sequence: -

0 - 9 The digits of the telephone number

P, T In the Dial command, these parameters switch to pulse-dialling (**P**) or to tone-dialling (**T**) until the other parameter is entered. The standard setting is pulse-dialling.

W Dialling tone recognition. When this parameter is entered, the modem will not continue dial until it has recognized the sign that the line is free. This is an advantage in branch exchanges, where it is not always possible to guarantee immediate access to a line.

, Dialling pause (1 sec). This command may not be used in the dialling sequence when the modem is supposed to wait for a new dial-tone. The **W**-parameter must be used in this case.

A-D,*,# Additional characters when tone-dialling

S=n Dialling number which is stored with **&Zn**

! Call exchange by Flash

^ Switch off calling tone; this applies only during the current dialling process

;H Modem as automatic dialling device. Here, the dialling sequence is terminated by a semi-colon, followed by the **H** command. The modem goes off-line after dialling and you can take over the conversation using a telephone. The handset must be lifted **during** the dialling process.

Example of how to set up a Dial Command

ATD T0 , P 02212971

With this, a private automatic branch exchange using tone-dialling dials zero, in order to obtain an exchange line. The modem then waits one second for the “line-free” tone so that it can dial the rest of the telephone number in pulse-dialling mode

Example of the Automatic Dialling Function

ATD T0 , P 02212971;H

If you lift the handset **during** the dialling process, you can take over the connection yourself.

- ⇒ *Where appropriate, ask the manufacturer of your private automatic branch exchange what specific features need to be taken into account in the dialling procedure*
- ⇒ *If the handset is not replaced after the data transmission has been completed, the connection remains made and you will continue to pay for this !*

E – Echo Function

The E command determines whether the modem will issue an echo of the command which is entered.

- ATE0** No command echoes are issued to the computer
- ATE1** Command echoes are issued (factory setting)

F – Determining Type of Modulation and Speed

The parameter of this command determines the type of modulation. It operates in conjunction with the N command and the S37 Register.

- ATF0** Automatic recognition of the remote modem's capabilities. Connections with all possible speeds are authorised. The S37 value and interface speed are ignored.
- ATF1** V.21 or Bell 103 (according to the **B** command)
- ATF3** V.23 (send 75 bps, receive 1200 bps)
- ATF4** V.22 1200 bps
- ATF5** V.22bis 2400 bps; Fallback to 1200 bps possible
- ATF6** V.32bis or V.32 4800 bps
- ATF7** V.32bis 7200 bps
- ATF8** V.32bis or V.32 9600 bps
- ATF9** V.32bis 12 000 bps
- ATF10** V.32bis 14 400 bps

H – Switch Hook Check (Replace Handset)

The H command will break off the existing telephone line connection (the modem “hangs up”) and the connection to the remote modem is cut off. After the H command, any other commands in the same line are ignored.

⇨ *This command can only be entered after an existing data link has been quitted by using the **Esc** sequence.*

I – Firmware Information

ATI0	Gives the Product Code
ATI1	Gives the ROM test total
ATI2	The test total is calculated and compared with the value stored in the ROM (Message is OK or ERROR)
ATI3	Gives the firmware version
ATI4	Gives the name of the device
ATI5	Gives the Country Code
ATI6	Gives the Data Pump model

L – Volume Level of Connected Loudspeaker

You can connect a loudspeaker to the modem, to enable you to follow acoustically as the connection is established and data are transmitted.

ATL0,1	Low volume (factory setting)
ATL2	Medium volume
ATL3	High volume

⇨ *The volume can also be adjusted at the modem itself.*

M – Switching the Loudspeaker On and Off

ATM0	Loudspeaker is always OFF
ATM1	Loudspeaker is ON until the carrier signal is recognized (factory setting)
ATM2	Loudspeaker is always ON
ATM3	Loudspeaker is OFF when dialling and after carrier tone recognition

N – Recognizing Type of Modulation

This command commands the automatic recognition of the type of modulation.

ATN0	Automatic recognition not authorised. The Handshake is carried out to the value of S37. Where S37=0, the Handshake is set to the interface speed
ATN1	Automatic recognition is authorised (as F0)

O – Return to On-Line Operation

The O command causes the modem to return to Online mode, which can be left temporarily, using the Esc sequence.

P – Selecting Pulse Dialling

This command specifies pulse-dialling as the standard dialling procedure, until the modem receives a Tone-dialling parameter in a dialling command, or until the T command is received.

Q – Modem Messages On / Off

ATQ0 Modem messages are issued (factory setting)
ATQ1 Modem messages are not issued

S – Reading and Modifying Registers:

ATSn=v This sets Register n to the (decimal) value v
ATSn=v? This sets Register n to the (decimal) value v and sends the new value for checking
ATSn? This reads Register n and gives its value in decimal form

T – Selecting Tone Dialling

This command specifies tone-dialling as the standard dialling procedure, until the modem receives a Pulse-dialling parameter in a dialling command, or until the P command is received.

V – Verbal or Numeric Modem Messages

The V command determines the type of message which the modem returns to the computer.

ATV0 Numeric modem messages
ATV1 Verbal modem messages (factory setting)

W – Controlling Connect Messages

This command controls the format of CONNECT messages. Other options can be controlled via the value of S95.

ATW0 Once the connection has been established, only the interface speed is advised

- ATW1** Once the connection has been established, messages follow sequentially regarding the speed on the telephone line, the Error Protocol and the interface speed
- ATW2** Once the connection has been established, only the speed on the telephone line is advised

X – Extended Connect Messages; Making Connections

The X command determines which modem messages are authorised. Messages 0 to 4 are basic and are always issued.

Messages 5 to 81 are extended modem messages, which can be switched on or off by using the **X** command (see also the **W** command). The **X** command determines how the engaged tone will be handled (see also the **D** command).

- ATX0** The modem issues only messages 0 to 4. To dial, the modem goes on-line, waits for the period of time preset in the S6 register (standard is 3 seconds) and then dials, whether or not there is a dialling tone. Once the connection has been established, a CONNECT message is issued. If this is not achieved in the time laid down in the S7 Register (standard is 60 seconds), a NO CARRIER message is issued. The modem does not recognize dialling or engaged tones.
- ATX1** The modem issues all messages. If the W parameter is used in the Dialling command but no dialling tone is recognized, a NO CARRIER message is issued.
- ATX2** The modem waits for a dialling tone and gives a NO DIALTONE message if the dialling tone is not recognized within the time set in the S6 Register. The engaged tone is not recognised.
- ATX3** The modem issues all messages. The dialling method is as for the **X0** command; however, the busy tone is recognized and quitted with a BUSY message.
- ATX4** The modem dials blind, issues all messages and recognizes the engaged tone (factory setting).

Y – Long Space Disconnect

The Y command determines whether the modem recognizes a “Long Space Disconnect” signal, that is, whether it will shut down the line if a Space signal of longer than 1.6 seconds is received from the remote modem.

- ATY0** Space signal not recognized (factory setting)
- ATY1** Space signal is recognized. In “Normal” and “Direct” connections, the modem will send a Space signal 4 seconds before shut-down before proceeding to “hang up”. Where the connection includes Error correction, it will go direct from the line.

Z – Reset/Load a Stored Profile

The Zn command is used to carry out a Reset of an active configuration profile. In this procedure, the NVRAM values are written into the relevant Registers and the remaining parameters are changed again to the factory settings. You use the n parameter to select one of the configuration profiles which has been stored with &W (n=0,1). Any command following the Z command in the same command line will be ignored.

&C – M5 Control Line

The M5 signal at the serial interface to the DTE is always made with the &C0 command and the current status of the carrier signal from the remote modem is ignored. With the &C1 command (factory setting), the M5 signal (DCD: Data Carrier Detect) displays the condition of the carrier signal which is received.

&F – Loading the Factory Settings

The &Fn command (n = 0,1) is used to read any of the factory settings stored in the ROM. Any modified preliminary settings are over-written by this.

The **&F1** setting is specially intended for initialisation in the BTX operating mode, while **&F0** is used for general data transmissions.

A Selection of &F0 Factory Settings

E1	Echo On
L0	Associated loudspeaker on low volume
M1	Loudspeaker On until connection is made
Q0	Modem messages switched on
V1	Complete alpha-numeric messages
Y0	Long Space Disconnect switched off
X4	Wait for dialling tone; engaged tone recognition
&B0	CCITT
&C1	M5 displays carrier recognition
&D2	Modem “hangs up” when S1 line (DTR) goes off
&G0	Guard tones switched off
&R1	M2 always On
&T4	Modem reacts to test loop request from remote party
S0=0	No automatic answer
\N3	Automatic operational mode dialling (buffering)

(Further settings are covered by the descriptions of the individual Commands and Registers).

&G – Guard Tone

In the Answer mode (upper channel transmission), the unit can send a Guard tone which in certain circumstances is a requirement for connections to the UK from abroad. With Bell 212A and Bell 103, no Guard tone is transmitted.

AT&G0,1 Guard tone Off (factory setting)

AT&G2 1800 Hz Guard tone

&K – Flow Check

This command determines the type of computer/modem flow check: -

AT&K0 No flow check authorised

AT&K3 RTS/CTS flow check authorised (standard for data modem operation), (factory setting).

AT&K4 XON/XOFF flow check authorised

AT&K5 Transparent XON/XOFF flow check

AT&K6 XON/XOFF and RTS/CTS flow check authorised (standard for fax modem operation)

&M – Asynchronous Dialling / Synchronous Data Transmission

With this command, once the modem has dialled (in asynchronous mode) it can change over to data transmission in synchronous mode.

AT&M0 Commands and transmission are asynchronous (factory setting)

AT&M1 This mode is used with terminals which can operate asynchronously or synchronously. The modem goes to synchronous mode for the entire period of data transmission

AT&M2 Same as **&M1**; in addition, when the S1 (DTR) signal changes from On to Off, the number stored with **AT&Z0** will be dialled.

&Q – Synchronous / Asynchronous

This command extends the functions of the **&M** command and is used for controlling authorised types of connection.

AT&Q0-2 Same as **&M0-2**

AT&Q4 *Hayes Autosync Operational Mode*: This modem supports *Autosync*, the Hayes Method of synchronous communication. Used in conjunction with the “Hayes Synchronous Interface” (HSI), this system permits synchronous communication with mainframe computers from an asynchronous terminal (PC). This requires no additional synchronous PC boards and the modem can change the operating mode without any configuration modification (see also Registers 19, 20 and 25).

- AT&Q5** The modem attempts to create a data link with Error correction. You can also specify in Register S36 whether the modem should go off-line or create an asynchronous link, if this is unsuccessful.
- AT&Q6** Asynchronous operation in “Normal” mode. (factory setting)

&R – Control Lines S2 and M2

In asynchronous operation (see also &M0 command), the M2 control line (106/CTS) is always set up, whether in command mode or in data mode. Where synchronous operation is involved (&M1 to &M3), the following commands apply:

- AT&R0** M2 (106/CTS) follows S2 (106/RTS). Where S2 changes over from On to Off, M2 switches on after the period of time specified in the S26 Register. In the M2-OFF status, any data received is ignored.
- AT&R1** The modem ignores S2 (the assumption is that S2 is on, so that M2 is also on) (factory setting)

&S – Control Line M1 (107/DSR)

With the &S0 command, the M1 control line is always set up when the modem is switched on. The effect of the &S1 command (factory setting) is to retain the M1 (DSR) in accordance with CCITT recommendations V.22bis/V.22.

&T – Modem Test Functions

A number of diagnosis commands are available, to enable you to limit any communication problems. These can be entered only when the system is in Command mode (or in Esc command mode for remote test loops). To use them, the following procedures must be carried out: -

- Set the communications software to 9600 bps
 - Send the command **AT\N1 F8** to the modem
- ⇒ *In order to disengage the local or remote digital test loops, a telephone connection must first be created, from which you can use the **Esc** sequence to go into the **Esc** command mode*

- AT&T0** End the current test loop and issue an Error report
- AT&T1** Start a local, analogue test loop in order to check the computer/modem and modem/computer links. During this process, the inputs from your keyboard should be correctly displayed on the screen.
- AT&T3** Start a local, digital test loop, in which any data transmitted by a remote modem is returned to it.
- AT&T4** Authorise a remote digital test loop for the remote modem (factory setting)
- AT&T5** Stop the remote digital test loop

- AT&T6** Enquiry for a remote digital test loop. For this, the **Esc** sequence must be entered **in an existing connection** and AT&T4 must be active at the remote modem
- AT&T7** Enquiry for a remote digital test loop with Self-Test (see &T6). The “Self-Test” consists of a test sample, which is sent locally. At the end of this test, the number of errors detected will be reported to the computer.
- AT&T8** Start a local analogue test loop with Self-Test
- ☞ *You can use the Test Timer (Register 18) to end a test loop; alternatively, once you have entered the Esc sequence (+++), you can enter the command AT&T0.*

&V – Displaying the Current Configuration

This command can be used to cause the modem to display the current modem configuration, the configurations stored under &W and the first four stored telephone numbers.

Table 2 Current Modem Configuration (Example)

```
ACTIVE PROFILE:
B0 E1 L1 M1 N1 P Q0 V1 W0 X4 Y0 &C1 &D2 &G2 &J0 &K3 &Q5 &R1 &S1 &T4 &X0 &Y0
S00:000 S01:000 S02:043 S03:013 S04:010 S05:008 S06:003 S07:060 S08:001 S09:006
S10:014 S11:090 S12:050 S18:000 S25:005 S26:001 S36:007 S37:000 S38:020 S44:020
S46:138 S48:007 S95:002

STORED PROFILE 0:
B0 E1 L1 M1 N1 P Q0 V1 W0 X4 Y0 &C1 &D2 &G0 &J0 &K3 &Q5 &R1 &S1 &T4 &X0
S00:000 S02:043 S06:003 S07:060 S08:001 S09:006 S10:014 S11:090 S12:050 S18:000
S36:007 S37:000 S40:105 S41:131 S46:138 S95:002

STORED PROFILE 1:
B0 E1 L1 M1 N1 P Q0 V1 W0 X4 Y0 &C1 &D2 &G0 &J0 &K3 &Q5 &R1 &S1 &T4 &X0
S00:000 S02:043 S06:003 S07:060 S08:001 S09:006 S10:014 S11:090 S12:050 S18:000
S36:007 S37:000 S40:105 S41:131 S46:138 S95:002

TELEPHONE NUMBERS:
0= 1=
2= 3=
```

&W – Storing a set Profile

The &Wn command is used to store a number of values of the S Register's current configuration profile, in the non-volatile NVRAM. You can store two different profiles (n = 0, 1) and load these again by using the Z command.

&X – Setting the Clock Signal in Synchronous Mode

The &X command determines down how the Clock Signal is produced.

AT&X0	The modem produces its own send-pulse (factory setting)
AT&X1	The modem awaits the send-pulse from the computer
AT&X2	The modem produces the send-pulse from the pulse which it receives (pulse loop). This command must not be active simultaneously with two connected modems.

&Y – Selecting a Start Configuration

The &Yn command is used to determine which of the non-volatile stored profiles (&W command) will be active when the unit is switched on. The n parameter (n = 0, 1) is used to select the profile required (factory setting is 0).

&Z – Telephone Number Storage

The modem can store up to 20 telephone numbers by using the AT&Zn=x command (n = 0-19). These can be dialled automatically by the command ATDS=n. Telephone numbers must not be more than 40 characters in length (digits + dialling parameters).

For example: **AT&Z7=P06897 123456**

The telephone number P (for pulse dialling) 06897 123456 is stored in memory 7.

\A – Maximum MNP Block Size

The \A command determines the maximum size of the data blocks for MNP4 and MNP5 connections but not for MNP1-3. Where good telephone lines exist, large data blocks will speed transmission, because the quantity of additional bits is less.

With poor telephone lines it is more sensible to transmit small data blocks as if there is an error, the entire data block will have to be sent again.

AT\A0	Maximum block size is 64 bytes
AT\A1	Maximum block size is 128 bytes
AT\A2	Maximum block size is 192 bytes
AT\A3	Maximum block size is 256 bytes (factory setting)

\B – Sending a Break Signal

The \B command is used to send a Break signal to the remote modem (see \K command).

In order to enter the \B command, you must first return from the existing data connection to the Command mode, using the **Esc** sequence. The Break signal is fixed at 300 ms.

\F – Displaying the Telephone Number Store

The command `AT\F` displays the telephone numbers stored with `AT&Z`.

\G – Modem/Modem Flow Check

The `\G` command determines whether the modem/modem Flow Check is switched on during a “Normal” connection. This Flow Check supports the modem, if data are sent more quickly than they can be handled.

If the MNP buffer is full, it will send an XOFF signal (13A decimal) to the computer, so that it will interrupt the data transmission. As soon as the buffer store is ready to accept data again, the modem sends an XON signal (11 decimal), whereupon the computer takes up the data transmission again.

`AT\G0` XON/XOFF Flow Check OFF (factory setting)

`AT\G1` XON/XOFF Flow Check ON

\J – Baud rate Adjustment via the Computer

The `\J` command determines whether the speed of transmission from modem to computer will be adjusted to the speed of transmission along the telephone line.

`AT\J0` Baud Rate Adjustment OFF. The modem/computer transmission speed remains unchanged at the interface, without taking account of the speed between modem and modem. If the interface speed is set to more than 14 400 bps, or where MNP connections are authorised, you must apply a method of Flow Checking (either RTS/CTS or XON/XOFF - see `\Q` command) in order to ensure that the buffer does not “overflow” and cause data to be lost.

`AT\J1` Baud Rate Adjustment ON. The computer adjusts the speed at the RS-232 interface to the speed of data transmission on the telephone line. You can use this adjustment system, when the computer adjusts to the correct speed as a result of modem messages. (Autobaud) (factory setting).

\K – Type of Break Control

The \K command determines how the modem by-passes with a Break signal.

Table 3 Break Control

	Break by Computer in Data Mode	Break by Computer in ESC-Command Mode	Break by Remote Modem in “Normal” Connection
\K0	No break to remote modem; go into ESC command mode	Delete buffer send Break immediately to remote modem	Delete buffer and send Break to computer
\K1	Delete buffer send break to remote modem	as \K0	
\K2	as \K0	Send Break immediately to remote modem	Send Break immediately to computer
\K3	Send Break immediately to remote modem	as \K2	as \K2
\K4	as \K0	Send Break in Data sequence to remote modem	Send Break in Data sequence to computer
\K5*	Send Break in Data sequence to remote modem	as \K4	as \K4

\L – Determining Block/Stream Mode with MNP

This command is used to determine the transmission mode with MNP connections.

AT\L0 Stream Mode: maximum block size is determined with \A

AT\L1 Remote modem block mode is authorised

\N – Data Transmission Mode

The \N command is used to set up the preferred data transmission mode (Direct, Normal, MNP or V.42bis).

AT\N0 The modem tries to create a “Normal” connection (without data compression and Error correction). The intermediate store is used for buffering, as with an MNP connection. This data buffering permits different data rates at the interface and on the telephone line.

AT\N1 The modem makes a direct connection to the remote modem. No MNP is used and the Baud rate at the interface is adjusted to the Baud rate on the telephone line. To achieve successful data transmission, the data rate of the computer must, where appropriate, be adjusted to the transmission speed.

AT\N2 The modem first tries to make a V.42 connection and then an MNP connection (Reliable). Where no Error Check is authorised at the remote modem, the modem will break off the connection and return to Command mode.

- AT\N3** Depending on the remote modem setting, the modem tries to make a Normal, MNP or V.42 connection (Auto reliable). Hardware Flow Check is authorised (factory setting).
- AT\N4** The modem tries to make a V.42 (Reliable) connection
- AT\N5** The modem tries to make an MNP (Reliable) connection.
- ☞ *Some types of modem will not accept an MNP connection. In such cases, use the \N0 command (Buffering) or the \N1 command (Direct mode).*

IS – Displaying the Configuration

If you enter AT\S0 the current modem configuration will be displayed, thus giving you an overview of many different settings.

Table 4 Active Configurations Display (Example)

CMD	DESCRIPTION / OPTION	CMD	DESCRIPTION / OPTION	CMD	DESCRIPTION / OPTION
	DTE BPS.....19200	&C	DCD OPTION.....1)M	CELLULAR.....OFF
	DTE PARITY.....NONE	&D	DTR OPTION.....2	S0	RINGS TO ANS.....000
	DIAL MODE.....PULSE	&G	GUARD TONE.....1800	S1	RING COUNT.....000
	LINE SPEED.....NONE	&K	FLOW CONTROL.....RTS	S2	<ESC> CHAR.....043
B	BELL MODE.....OFF	&L	NETWORK.....PSTN	S3	<CR> CHAR.....013
E	CMD ECHO.....ON	&P	PULSE MODE.....0	S4	<LF> CHAR.....010
F	LINE MODE.....AUTO	&Q	ASYNC/SYNC.....5	S5	<BS> CHAR.....008
L	SPKR VOLUME.....LOW	&R	RTS/CTS.....1	S7	CONNECT TIME.....060
M	SPKR CONTROL.....1	&S	DSR OPT.....1	S8	PAUSE TIME.....001
N	AUTO MODE.....ON	&T	ENABLE RDL.....YES	S12	ESC GUARD TIME...050
Q	QUIET.....OFF	&X	SYNC CLOCK.....INT	S24	SLEEP INACT.....010
V	RESULT FORM.....LONG	&Y	PROFILE.....NO	S30	CONNECT INACT.....000
W	EC MSG.....0	\A	MAX BLK SIZE.....128	S32	XON CHAR.....017
X	EXT RESULTS.....4	\G	REMOTE FLOW.....OFF	S33	XOFF CHAR.....019
Y	LONG SPACE DISC...NO	\K	BRK OPT.....5	S36	FALLBACK ACTION..007
%C	COMPRESSION.....BOTH	\N	ECL MODE.....AUTO	S37	MODE SELECT.....000
%E	AUTO RETRAIN.....OFF	\W	SPLIT SPEED.....OFF	S48	V42 NEG CTRL.....007
-K	EXT. SERVICES.....1	*H	NEG. SPEED.....HIGH	S95	RES. CODE.....002

IW – Split Speed Operation

- AT\W0** Not authorised (factory setting)
- AT\W1** Authorised. V.23 operation is enforced, as with **F3**.

-K – Extended MNP Operation

This command determines whether the conversion of a V.42 connection to an MNP connection is authorised.

- AT-K0** Not authorised
- AT-K1** Authorised (factory setting)

%C – Authorise Data Compression

By using the %C command, you can select data compression for MNP or V.42. For the compression to work, the remote modem must also have the capability for data compression and a Reliable mode (\N2, \N3 or \N4) must be active.

- AT%C0** Compression not authorised
- AT%C1** MNP 5 compression authorised
- AT%C2** V.42bis compression authorised
- AT%C3** Both compression procedures authorised (factory setting)

⇒ *Where files selected for transmission are compressed, the speed of transmission is reduced with MNP5 or V.42 Protocols.*

%E – Automatic Retrain

This command determines whether the modem will try to synchronize again with the remote modem, if conditions change on the telephone line.

- AT%E0** Automatic Retrain not authorised (factory setting)
- AT%E1** Automatic Retrain when line conditions deteriorate

%F – 75Tx/1200Rx or 1200Tx/75Rx in V.23 Mode

This command sets the transmission direction of the 75 or 1200 bps channel. This must firstly be enabled with the W1 command.

***H – Handshake Speed with MNP 10 Modem:**

This command controls the Handshake speed before an MNP 10 connection is agreed.

- AT*H0** Handshake at maximum possible speed (factory setting)
- AT*H1** Handshake at 1200 bps

***C – Password for Remote Configuration**

When AT*C is entered, the modem will issue a message OLD PASSWORD. The factory setting for this is the password QWERTY. Only when you have entered the correct old password will you be given the request NEW PASSWORD. Then, you can enter your own password (an alpha-numeric sequence of between 6 and 12 characters) and then, when you receive the message and request CONFIRM, you must repeat it. This stores your new password. The local modem can only be configured by a remote modem of the same type when this password is recognised.

⇒ *Remote configuration will function only with MNP connections (AT\N5).*

*R – Remote Configuration

Once you have entered the command *R at the local modem, the remote modem can be configured via the telephone line. (Only a limited set of commands is active here). To use this facility, proceed as follows: -

1. Enter **ATS80=65** at the modem to be configured (the remote modem) in order to authorise remote configuration.
2. Initialise the remote modem with **ATZ**
3. Make the MNP connection (**AT\N5**)
4. Enter the Esc sequence (**+++**) at the local modem
5. Enter **AT*R** at the local modem. This results in the request **REMOTE PASSWORD** and here you must enter the password which was stored for the remote modem with *C. Once the correct password has been entered, you will receive the message **!AT** and you can enter commands, in order to configure the remote modem.

☞ *Remote modem configurations are entered without the initial "AT"*

☞ *To refuse a remote configuration, the value of the Register 80 must be reset to 1 (ATS80=1; then ATZ).*

*E – End Remote Configuration

Entering the command *E at the local modem will end the remote configuration. The modem connection remains and you can return to Online Data mode by entering AT0.

*P – Password for Automatic Callback

You can use the command **AT*Pn** (where n = 0 - 19) to store passwords with their related telephone numbers. The format is as follows

AT*Pn:<password>:<telephone number>

The password must be between 6 and 12 characters (digits or letters), while the telephone number can be up to 40 characters in length. The password and telephone number must be separated from each other by a colon.

The local modem can then be required by the remote modem to call any one of the stored numbers. To do so, the following settings must be made at the local modem

1. **ATS80=129** and then **ATZ** (which causes the local modem to request the password after the connection has been made). Then, when the request

ENTER PASSWORD has appeared, a password which is stored in the local modem must be entered at the remote modem.

2. ATSO=1 (so that the modem goes on-line)

Provided the local modem recognizes a valid password, it will break off the connection and, after 10 seconds, it will dial the telephone number represented by the password in question.

⇒ *To switch off Automatic Callback, the value of Register 80 must be reset to 1 (ATS80=1, then ATZ).*

***L – Displaying Callback Numbers**

When this command has been entered, the modem gives a list of passwords with their related callback numbers.

```
O-MODEM1:08154711
1-RIVER_BEND:0815
2-AT_HOME:1234567890
3-SENSURY_SYS:0987654321
4-
.
.
.
18-
19-MAILBOX_GCS:4711
```

In order to change from the Hayes to V.25bis command setting and vice-versa, the value of Register 80 must be changed in each case.

- AT\$80=33 (Change from Hayes to V.25bis Commands)
- CNLS80=1 (Change from V.25bis to Hayes Commands)

⇒ *Changes become active only after a modem reset (ATZ or CNLZ).*

To carry out a dialling operation in V.25bis, the modem must be in Command mode and must receive the **CRI** command from the computer, containing the following dialling information:

CRIxx...x;yy...y

or **CRIxx...x**

In these, the Variable *x* represents the sequence of characters to be dialled (telephone number with dialling parameters), while the Variable *y* covers identification (optional) which is issued after an unsuccessful dialling operation.

For example:

CRI>=06897<<12345;67890

CRI dialling command

=	Dialling pause 3 seconds
06897	STD code
<<	Dialling pause 2 seconds
12345	Telephone number
;	separation character
67890	Your own identification code (your own telephone number)

Another example:

CRSn The modem dials the number which is stored with **AT&Z=n**

In addition, the command **CNLnn** enables you to use the **AT** commands to set up an MNP connection, or to switch over the MNP mode. Here, the Variable **nn** represents all the **AT** commands. The following tables show the commands and messages with CCITT V.25bis and the valid dialling parameters.

Table 5 Commands and Modem Messages with V.25bis

Command/Message	Character Sequence
Connection Request	CRlxx...x;yy...y
Call Number	xx...x (dialling character sequence)
Identification Number	yy...y (identification number)
Connection Request	CRNxx...x
Call Number	xx...x (dialling character sequence)
Polling AT commands	CNLnn (nn=AT command syntax)
Message with unsuccessful Connection request (Call Failure Identification)	CFLxx
Break off dialling	CFI AB
Own connection busy (DCE busy)	CFI CB
Busy tone recognized	CFI ET
Answer tone not recognized	CFI NT
Number is not accessible	CFI FC
Connection message	CNX (e.g. CNX 9600)
INCOMING CALL message	INC
VALID message	VAL
INVALID message	INV
Automatic Answering system (AAE) OFF (Disregard Incoming Call)	DIC
Automatic Answering system (AAE) ON (Consider Incoming Call)	CIC

Table 6 Dialling Parameters for V.25bis

Parameter	Description
0 to 9	Digits of telephone number
P	Pulse dialling
T	Tone dialling
*#	Additional tone dialling characters
:	Wait for dialling tone
W	
<	Short dialling pause (duration set in Register 8)
=	Long dialling pause (double value of S8)
&	Hook flash (to get a line in private automatic branch exchange)
;	Separation character between telephone number and identification

The modem responds to AT commands with *Modem Messages*. You can control their format (verbal or numeric) with the **V** command.

In addition, the modem issues *Connection Messages*, when it recognizes activities on the telephone line. The **X** command determines which messages are authorised here.

Messages regarding Error correction are controlled via the **W** command and with the S95 Register. The following table gives an overview of the possible messages.

Numeric/ Verbal	Reason/Description
(00) OK	Modem acknowledges execution of a command
(01) CONNECT	<ol style="list-style-type: none"> 1. Modem has created a data link at 300 bps 2. Interface speed is 300 bps when link is made 3. Link is made but X0 command is on and modem issues no information on speed
(02) RING	Modem has recognized an incoming call
(03) NO CARRIER	<ol style="list-style-type: none"> 1. "Free" signal recognized but no carrier in specified time 2. No "Free" signal recognized in specified time (S7) 3. Modem gone off-line following loss of carrier 4. Answer when engaged signal is recognized 5. Answer when no dialling tone is recognized
(04) ERROR	<ol style="list-style-type: none"> 1. Modem has found an error in the command syntax or cannot carry out the command line 2. Dialling blocked (X0, X1, X2 or X3 are engaged) 3. Telephone handset not replaced
(05) CONNECT 1200	<ol style="list-style-type: none"> 1. Modem has set up a data link at 1200 bps 2. Interface speed is 1200 bps after link is made
(06) NO DIALTONE	X2 or X4 is active and modem has not received a dialling tone
(07) BUSY	X3 or X4 is active and modem has received an engaged tone after dialling
(08) NO ANSWER	Modem recognizes "Free" signal until time set in S7 Register has expired

(09) CONNECT 0600 (10) CONNECT 2400 (11) CONNECT 4800 (12) CONNECT 9600 (13) CONNECT 7200 (14) CONNECT 12000 (15) CONNECT 14400 (16) CONNECT 19200 (17) CONNECT 38400 (18) CONNECT 57600	Where X1, X2, X3 or X4 is active, these messages show the interface speed, or the speed on the line, once the data connection has been made
(22) CONNECT 75TX/1200RX	Modem has created a V.23 link in Originate mode
(23) CONNECT 1200TX/75RX	Modem has created a V.23 link in Answer mode
(24) DELAYED hh:ss:mm	Where X4 is active, this message shows dialled number is inaccessible
(32) NO MORE DIALLING	Modem goes into "Dialling Blocked" for 2 hours. This can be caused by a power supply failure
The following messages apply where a carrier is recognized on the telephone line and S95=2 is active.	
(40) CARRIER 300 (44) CARRIER 1200/75 (45) CARRIER 75/1200 (46) CARRIER 1200 (47) CARRIER 2400 (48) CARRIER 4800 (49) CARRIER 7200 (50) CARRIER 9600 (51) CARRIER 12000 (52) CARRIER 14400	V.21 or Bell 103 carrier recognized V.23 Backward-Channel carrier recognized V.23 Forward-Channel carrier recognized V.22 or Bell 212 carrier recognized V.22bis carrier recognized Data rate of 4800 bps recognized in V.32 or V.32bis mode Data rate of 7200 bps recognized in V.32bis mode Data rate of 9600 bps recognized in V.32bis or V.32 mode Data rate of 12000 bps recognized in V.32bis mode Data rate of 14400 bps recognized in V.32bis mode
(66) COMPRESSION CLASS 5	Modem has set up a link with MNP 5 and compression messages are authorised
(67) COMPRESSION V.42bis	Modem has set up a link with V.42bis and compression messages are authorised
(69) COMPRESSION NONE	Modem has set up a link without data compression and compression messages are authorised
(76) PROTOCOL NONE	Modem has set up a link with no form of Error correction and messages covering Error correction are authorised
(77) PROTOCOL LAPM	Modem has set up a link with V.42 Error correction
(80) PROTOCOL ALT	Modem has set up a link with MNP Error correction
(81) PROTOCOL ALT CELLULAR	Modem has set up a link with MNP 10 Error correction (specially suitable for radio telephones)

The modem has a series of S-Registers, in which the active configurations are stored. The contents of a number of Registers are stored in a non-volatile memory (NVRAM), which can be interrogated with **Z**, **&Y** and **&W** commands. The syntax for entering and requesting Register values is given in the description of the **S** command. The values of most of the Registers can be modified by using AT commands.

Table 7 S-Registers (Summary)

Register	Range	Default.	Description
S0*	0-2 ring characters	0	Ring characters before modem answers
S1	0-255	0	Ring character counter
S2*	0-127 ASCII	43	Esc sequence character
S3	0-127 ASCII	13	Carriage return character
S4	0-127 ASCII	10	Line feed character
S5	0-127 ASCII	08	Backspace character
S6*	5-40 sec	10	Dial tone waiting time
S7*	0-60 sec	40	Waiting time for carrier after dialling
S8*	0-10 sec	1	Pause character comma
S9*	1-255 1/10 sec	6	Answer time after carrier recognition
S10*	14-100 1/10 sec	14	Delay: carrier loss to "hanging up"
S12*	0-255 1/50 sec	50	Guard time for Esc sequence
S14*	Bit-mapped	170 (AAh)	General options
S16	Bit-mapped	00	Modem test options
S18*	0-255 sec	0	Test Timer
S21*	Bit-mapped	116 (74h)	V.21/General options
S22*	Bit-mapped	117 (75h)	Loudspeaker/modem messages
S23*	Bit-mapped	63 (3Fh)	General options
S24*	1-120 sec	60	Inactivity timer for Low Power Operation
S25	0-255 sec; 1/100 sec	5	DTR delay time
S26	0-255 1/100 sec	01	Delay from RTS to CTS
S27*	Bit-mapped	9	General options
S28*	Bit-mapped	0	General options
S29	Fixed 10 ms	2	Flash Dial Modifier Time
S30	0-255 10 sec	0	Inactivity timer for "hanging up"
S31*	Bit-mapped	194 (C2h)	General options
S32	0-255 ASCII	17	XON character
S33	0-255 ASCII	19	XOFF character
S36*	Bit-mapped	7	Fallback with V.42 link creation
S37*	Bit-mapped	0	Type of modulation (Line-Speed)

Register	Range	Default.	Description
S38	0-255 sec	20	Delay before “hanging up”
S39*	Bit-mapped	3	Flow check
S40*	Bit-mapped	105 (69h)	General options
S41*	Bit-mapped	131 (83h)	General options
S46*	Bit-mapped	138	Control data compression
S48*	Bit-mapped	7	Control V.42 handshakes
S80	Bit-mapped	1	Soft Switches
S82	-	128 (40h)	Handling Break character
S86	0-255	-	Error Codes for NO CARRIER-messages
S95*	Bit-mapped	0	Controlling extended connection messages
*Register values are stored with &W in the non-volatile NVRAM memory			

S0 – Number of Ring Characters before Modem engages

Where the value of S0 = 0, automatic answering is switched OFF and the modem does not go on-line. Where the value of S0 = 1, the modem goes on-line at the first ring sign, or character.

Range: 0-2 ringing characters; factory setting: 0

S1 – Ring Character Counter

The value of this Register is increased by 1 with each ring character which is recognized. It is deleted when pauses exceed 8 sec.

Range: 0-255 ring characters; factory setting: 0

S2 – Esc Sequence Character

ASCII value of the character defined as the Esc sequence, to change from data mode to command mode. The Esc sequence is switched off where this value exceeds 127.

Range: 0-255; factory setting: 43 (ASCII+, “plus” sign)

S3 – Carriage Return Character

ASCII value of the Carriage Return character (<CR>Carriage Return) ends the command lines and modem messages.

Range: 0-127; factory setting: 13 (ASCII CR, Carriage Return)

S4 – Line Feed Character

ASCII value of the Line Feed character (<LF> Line Feed). The modem sends this character after <CR> to finish verbal modem messages in asynchronous operating mode.

Range: 0-127; factory setting: 10 (ASCII LF, Line Feed)

S5 – Backspace Character

ASCII value for Backspace. Entering this will delete the character to the left of the cursor (and the last character in the command memory) and the cursor moves one space backwards.

Range: 0-32, 127; factory setting: 8 (ASCII Backspace)

S6 – Waiting Time for Dialling Tone

The value of the S6 Register determines when the modem will begin to dial after “lifting the handset” (or after recognizing the W parameter in Dialling command mode). The X command controls the effect of the S6 Register. For X0, X1 or X3, the modem waits for the specified period, even if the dialling tone occurs earlier. You can enter any value between 0 and 255 sec in this Register; however, the modem will always wait a minimum 2 seconds, even if you enter a lower value.

Range: 5-40 seconds; factory setting: 10 sec

S7 – Waiting for Carrier Signal

Where the extended mode commands X3 or X4 are active (X4 is the factory setting), the modem waits in Originate mode until the “Free” character is recognized (the other connection is being called). The value of the S7 Register determines the duration of the waiting period. In addition, the value of the S7 Register also determines how long the modem will wait for a carrier signal from the remote modem, before it “hangs up”. Since the modem also waits for a carrier signal, if it does not recognize a “Free” tone, the total waiting time can be twice as long as the value set in the S7 Register.

When answering, the Register value represents only the waiting time for carrier-tone recognition, since the “Free” character is of no importance here. Further, the value of the S7 Register determines the waiting time for a subsequent dialling tone (with no affect on the waiting time after the modem has “lifted the handset”), where the W parameter is in Dial command mode. The subsequent dialling tone is used in telephone systems, where a number is dialled beforehand to call the exchange.

Range: 0-60 sec; factory setting:40 sec

S8 – Pause Time after Comma

If a comma is included in the Dial command, the modem will pause when dialling, when it reaches this character. The length of this pause is determined by S8.

Range: 0-10 sec; factory setting: 1 sec

S9 – Answer Time after Carrier Recognition

The period of time, during which the carrier from the remote station must be present, before the modem goes on-line. A higher value decreases the risk of an incorrect interpretation.

Range: 1-255 1/10 sec; factory setting: 6 (0.6 s)

S10 – Delay between Carrier Loss and Hanging Up

The period of time, during which the modem waits after carrier loss, before it “hangs up”. This allows for a temporary loss of the carrier. The value must be greater than the value of the S9 Register, so that the modem does not “hang up” before recognizing the carrier.

Range: 14-100 1/10 sec; factory setting: 14 (1.4 s)

S12 – Guard Time for Esc Sequence

The Guard Time is the period of time during which, both before and after entering the Esc sequence (+++), the modem is not permitted to receive any characters. Where the Register value is zero, the modem will always go into Command mode after three consecutive Esc signs.

Range: 0; 20 to 255 sec; interval 20 ms Factory setting: 50 (1 sec)

S14 – General Options

Factory setting: 170 (AAh) (10101010b)

Bit 0	Reserved
Bit 1	Command echo (E command)
0	Echo OFF (E0)
1	Echo ON (E1)(factory setting)
Bit 2	Modem messages (Q command)
0	Modem messages ON (Q0) (factory setting)
1	Modem messages OFF (Q1)
Bit 3	Modem messages, verbal/numeric (V command)
0	Numeric modem messages (V0)
1	Verbal modem messages (V1) (factory setting)
Bit 4	Reserved
Bit 5	Pulse or Tone dialling (P and T dialling parameters)
0	Tone dialling (T)
1	Pulse dialling (P) (factory setting)
Bit 6	Reserved
Bit 7	Originate/Answer mode (A, D commands; R dialling parameter)
0	Answer mode
1	Originate mode (factory setting)

S16 – Modem Test Options

Factory setting: 0

Bit 0	Local analogue test loop
0	OFF (factory setting)
1	ON (&T1)
Bit 1	Reserved
Bit 2	Local digital test loop
0	OFF (factory setting)
1	ON (&T3)
Bit 3	Status of remote digital test loop
0	OFF
1	ON
Bit 4	Status of a remote digital test loop, disengaged by the remote modem
0	OFF (factory setting)
1	ON (&T6)
Bit 5	Remote digital test loop with Self-Test
0	OFF (factory setting)
1	ON (&T7)
Bit 6	Local analogue test loop with Self-Test
0	OFF (factory setting)
1	ON &T8)
Bit 7	Reserved

S18 – Test Timer

This determines the duration of a test loop, disengaged by &Tn. Where the Register value is zero, test loops must be ended with &T0 or with the H command.

Range: 0-255 sec; factory setting: 0

S19 – Autosync Register

Bit 0	Reserved
Bit 1	Synchronous protocol
0	BSC
1	HDLC
Bit 2	Control of “Address Detector”
0	Address Detector not authorised
1	Address Detector authorised
Bit 3	Non return to zero
0	NRZ1
1	NRZ
Bit 4	
0	Mark idle
1	flag or sync idle
Bit 5-7	Reserved

S20 – HDLC Address/BSC Synchronous Character

Range: 0-255; factory setting: 0

S21 – V.24/General Options

Factory setting :	116 (74h) (11100100b)
Bit 0,1	Reserved
Bit 2	Condition of Control Lines RTS (S2) and CTS (M2)
0	CTS always ON (&R0)
1	CTS follows RTS (&R1) (factory setting)
Bit 3,4	Reserved
Bit 5	Condition of Control Line DCD (M5)
0	(&C0)
1	(&C1) (factory setting)
Bit 6	Condition of Control Line DSR (M1)
0	(&S0)
1	(&S1) (factory setting)
Bit 7	Long Space Disconnect
0	(Y0) (factory setting)
1	(Y1)

S22 – Loudspeaker/Authorised Modem Messages

Factory setting : 117 (75h) (01110101b)

Bit 0,1	Volume
0	Low (L0) (factory setting)
1	Low (L1)
2	Medium (L2)
3	Loud (L3)
Bit 2,3	Loudspeaker Condition
0	Always OFF (M0)
1	OFF after carrier recognition (M1) (factory setting)
2	Always ON (M2)
3	ON during Handshake (M3)
Bit 4-6	Authorised modem messages
0	(X0)
4	(X1)
5	(X2)
6	(X3)
7	(X4) (factory setting)
Bit 7	Reserved

S23 – General Options

Factory setting : 63 (3Fh) (00111111b)

Bit 0	Authorise a remote digital test loop for remote modem
0	Not authorised (&T5)
1	Authorised (&T4) (factory setting)
Bit 1-3	Interface speed
0	0-300 bps
1	600 bps
2	1200 bps
3	2400 bps
4	4800 bps
5	9600 bps
6	19200 bps
7	Over 19200 bps
Bit 4,5	Parity
0	Even
1	Reserved

2	Odd
3	No parity (factory setting)
Bit 6,7	Guard Tone
0	No Guard Tone (&G0) (factory setting)
1	No Guard Tone (&G1)
2	Guard Tone 1800 Hz (&G2)

S24 – Current Saving Switch

This determines when the modem goes into a current saving switch, where it does not register activity at the interface, nor on the telephone line.

Range: 1-120 sec; factory setting: 60

S25 – DTR Delay Time

Period of time between the departure of DTR and “hanging up”. In synchronous operational mode, the measurement units are seconds, while in other operational modes they are hundredths of seconds.

Range: 0-255 sec (1/100 sec); factory setting: 5

S26 – Delay RTS to CTS

In synchronous operational mode only (and with &R0), this Register determines when the CTS is switched on after RTS has changed from Off to On.

Range: 0-255 sec (1/100 sec); factory setting: 1

S27 – General Options

Factory setting : 9 (9h) (000001001b)

Bit 0,1,3	Changeover Synchronous/Asynchronous (&M/&Q)
0,0	&M0 or &Q0
1,0	&M1 or &Q1
2,0	&M2 or &Q2
3,0	&M3 or &Q3
0,1	&Q4
1,1	&Q5 (factory setting)
2,1	&Q6
Bit 2	Reserved
Bit 4,5	Control Clock Signal
0	Internal (&X0) (factory setting)
1	External (&X1)

2	Impulse loop (&X2)
Bit 6	CCITT/Bell Mode (B) (only at 300 and 1200 bps)
0	CCITT (B0) (factory setting)
1	Bell (B1)
Bit 7	Reserved

S28 – General Options

Factory setting : 0

Bit 0	V.23 Split Speed
0	Not authorised (\W0) (factory setting)
1	Authorised (\W1)
Bit 1	V.23 Split Speed Direction
0	75 Tx (%F0) (factory setting)
1	1200 Tx (%F1)
Bit 2	V.23 Semi-Duplex
0	Not authorised (factory setting)
1	Authorised (%F3)
Bit 3-7	Reserved.

S29 – Flash Dial Modifier Time

Sets the length of time, in units of 10 milli seconds, that the modem will go on hook when it encounters the flash (!) dial modifier in the dial string.

Fixed Range: 2 (20 ms)

S30 – Inactivity Timer

This determines when the modem goes off-line, when no data are being sent or received. If no Error Correction procedure is active, this Register is reset only by transmitted data. With other procedures, the Register is reset by any data which are recognized. The timer works only in asynchronous mode.

Range: 0-255 sec (1/10 sec); factory setting: 0

S31 – General Options

Factory setting :	194 (C2h) (11000010b)
Bit 0	Reserved
Bit 1	Controlling Automatic Speed Recognition (N)
0	Automatic Speed Recognition OFF (N0)
1	Automatic Speed Recognition ON (N1) (factory setting)
Bit 2,3	Controlling Extended Connection Messages (W)
0	Interface speed only (W0) (factory setting)
1	All information (W1)
2	Only modem speed (W2)
Bit 4-7	Reserved

S32 – XON Character

Determines the value of the XON character.

Range: 0-255 (ASCII); factory setting: 17

S33 – XOFF Character

Determines the value of the XOFF character.

Range: 0-255 (ASCII); factory setting: 19

S36 – Fallback on V.42 Connection Set-up

Factory setting :	7 (7h) (00000111b)
Bit 0-2	This value determines what is to be done when a V.42 connection is set-up unsuccessfully. The Fallback options immediately become active if the value of S48=128. If invalid values are entered, this Register returns to the factory setting.
0	Modem goes off-line
1	Modem seeks a Direct connection
2	Reserved
3	Modem seeks a Normal connection
4	Modem seeks to make an MNP connection and goes off-line if this is unsuccessful
5	Modem seeks to make an MNP connection and makes a Direct connection if this is unsuccessful
6	Reserved
7	Modem seeks to make an MNP connection and makes a Normal connection if this is unsuccessful (factory setting)
Bit 3-7	Reserved

S37 – Speed on the Telephone Line

Factory setting : 0

Bit 0-3 This Register is dependent on the value of the F command. If invalid values are entered, the Register returns to the factory setting.

0	Automatic speed recognition (F0) (factory setting)
1-3	300 bps (F1)
4	Reserved
5	1200 bps (F4)
6	2400 bps (F5)
7	V.23 (F3)
8	4800 bps (F6)
9	9600 bps (F8)
10	12000 bps (F9)
11	14400 bps (F10)
12	7200 bps (F7)

S38 – Delay before Hanging Up

This Register determines how long the modem will wait after it has received an H command (or after an ON/OFF movement of the DTR), before it goes off-line. It is active only with Error-corrected connections. This is to ensure that data in the modem buffer can still be transmitted before the connection is broken off. If data are lost nevertheless, the modem will send the message “NO CARRIER” after receiving the H command. Where it is possible to transmit all the data from the buffer in the predetermined time, you will receive an “OK”.

Range: 0-255 sec; factory setting: 20

S39 – Flow Control

Factory setting : 3 (3h) (00000011b)

Bit 0-2 Status of Flow Control

0	No Flow Control
3	RTS/CTS (&K3) (factory setting)
4	XON/XOFF (&K4)
5	Transparent (&K5)
6	Both methods (&K6)

Bit 3-7 Reserved

S40 – General Options

Factory setting :	105 (69h) (01101001b)
Bit 0	MNP 10 authorised
0	MNP 10 not authorised (-K0)
1	MNP 10 authorised (-K1) (factory setting)
Bit 1	Voltage adjustment for radio telephones
0	No adjustment possible (factory setting)
1	Adjustment authorised M1
Bit 2	Speed of MNP Handshake
0	Highest possible speed (*H0) (factory setting)
1	Speed 1200 bps (*H1)
Bit 3-5	Handling the Break Signal
0-5	\K0 to \K5 (factory setting is \K5)
Bit 6,7	MNP Block size
0	64 characters (\A0)
1	128 characters (\A1)
2	192 characters (\A2)
3	256 characters (\A3) (factory setting)

S41 – General Options

Factory setting	:131 (83h) (10000011b)
Bit 0,1	Determining Type of Compression
0	No compression authorised (%C0)
1	MNP 5 (%C1)
2	V.42bis (%C2)
3	MNP 5 and V.42bis (%C3) (factory setting)
Bit 2	Automatic Retrain
0	Automatic Retrain not authorised (%E0) (factory setting)
1	Automatic Retrain authorised (%E1)
Bit 3	Modem/Modem Flow Check
0	Flow check not authorised (\G0) (factory setting)
1	Flow check authorised (\G1)
Bit 4	Controlling Block Mode
0	Stream Mode (\L0) (factory setting)
1	Block Mode (\L1)
Bit 5-7	Reserved

S46 – Authorising a Data Compression

Range:	136 or 138; factory setting: 138
S46=136	Error Correction Protocol without Data compression
S46=138	Error Correction Protocol with Data compression (factory setting)

S48 – Directing the V.42 Handshake

Range:	0, 7 or 126; factory setting: 7
S48=0	No V.42 Handshake; attempt to make a V.42 connection
S48=7	The remote modem's capabilities are checked (factory setting)
S48=128	No V.42 Handshake, but direct Fallback. This setting can be used to force an MNP connection

S80 – Soft Switches

Factory setting :	1
Bit 0-4	Reserved
Bit 5	Switch-over, V.25bis/AT-command set
0	Select AT command set (factory setting)
1	Select V.25bis command set
Bit 6	Authorise remote configuration
0	Remote configuration not authorised (factory setting)
1	Remote configuration authorised
Bit 7	Password protection for automatic callback
0	Automatic callback not protected by password (factory setting)
1	Automatic callback protected by password

S82 – Treating the Break Signal

This Register determines how a Break Signal is sent to the remote modem.

Range:	3, 7 or 128; factory setting: 128
S82=3	Break Signal is immediately transferred; data integrity before and after the Break Signal remains unaffected
S82=7	Destructive: the Break Signal is transferred immediately. Data which the modem is treating at the time are destroyed
S82=128	Modem ties the Break Signal into the transmitted data. Data integrity before and after the Break Signal remains unaffected

S86 – Error Codes for NO CARRIER Messages

For every NO CARRIER message a value is written into this Register, which assists in discovering the cause of the error. In each case, the initial cause of the NO CARRIER message is recorded.

S86=0	Normal break of connection; no error
S86=4	Loss of carrier
S86=5	Remote modem has no V.42 capabilities
S86=9	No common protocol possible with remote modem
S86=12	Normal break of connection, initiated by remote modem
S86=13	Remote modem has not reacted after the 10th repeat of the same information
S86=14	Protocol error

S95 – Extended Connection Messages

This Register can be used to render various W-command settings inactive. With the bits listed below, the value 1 will allow the messages described, no matter what the W-command setting may be.

Bit 0	CONNECT message gives the modem speed
Bit 1	CONNECT XXXX REL messages for connections with Error correction (factory setting)
Bit 2	CARRIER XXXX connection messages authorised
Bit 3	PROTOCOL XXXX connection messages authorised
Bit 4	Reserved
Bit 5	COMPRESSION XXXX connection messages authorised
Bit 6,7	Reserved

Appendix TECHNICAL INFORMATION

Digital Interfaces

To set up a connection between modem and computer/terminal (DTE = Data terminal equipment), an interface cable with the following features is required: ISO 2110 (SUB-D 25) to V.42 with V.28 level

Table 8 Interface Cables to V.42

DIN	CCITT	DIN 41612	ISO 2110 SUB-D25	Wire function	Description	Direction Mod.-DTE
E2	102	16c	7	Operating earth	Frame GND	
D1	103	11c	2	Sende data	TxD	<<
D2	104	12c	3	Receive data	RxD	>>
S1	108	16a	20	Transmission line On DTE ready to operate	DTR	<<
M1	107	15c	6	Operational readiness	DSR	>>
S2	105	13c	4	Switch on transmitter	RTS	<<
M2	106	14c	5	Ready to send	CTS	>>
M3	125	19a	22	Incoming call	Ring Indicator	>>
M5	109	18c	8	Receiver signal level	DCD	>>
PS2	140	18a	21	Remote test loop ON	Remote Loopback Request	<<
PS3	141	14a	18	Local test loop ON	Local Loopback Request	<<
PM1	142	-	25	Display test mode		<<
T1	113	21a	24	Transmit clock to DCE	Transmit Clock DTE-Source	<<
T2	114	11a	15	Transmit clock from modem	Transmit Clock DCE-Source	>>
T4	115	13a	17	Receive clock from modem	Receive Clock DCE-Source	>>

Audio Jack

Loudspeaker 3.5 mm mono latching jack; impedance 42

LED Indicators

The LED indicators show the operating condition of the modem:

Display	Meaning and Function (Operating Condition)
POWER	Modem is ready for operation
ONLINE	Modem switched to transmission line
DSR	Answer tone is present
DCD	Modem has recognized carrier tone from remote modem
CTS	Modem is ready to send
RTS	Transmit request is present
DTR	Computer is ready for operation

GLOSSARY

A AE	Automatic Answering Equipment
AM	Amplitude Modulation
BPS	Characters per second
BSC	Byte Synchronous Communication (synchronous protocol)
DCE	Data Communication Equipment
DTE	Data Terminal Equipment
DPSK	Differential Phase-Shift Keying
DTE	Data Terminal Equipment (= DTE)
ETX	End of Text
FCS	Frame Checking Sequence
FM	Frequency Modulation
FSK	Frequency Shift Keying
HDLC	High Level Data Link Control (Synchronous Protocol)
LRC	Longitudinal Redundancy Check
MFV	Multi-Frequency Dialling Procedure (= Tone Dialling)
MNP	Microcom Networking Protocol (Process for Error Checking and Data Compression)
oK	Upper Channel
PM	Phase modulation
PSK	Phase Shift Keying
QAM	Quadratic Amplitude Modulation
Retrain	renewed Synchronisation of Modem where Line Conditions have changed
SDLC	Synchronous Data Link Control (synchronous protocol)

STX	Start of Text
SYN	Synchronous Character
uK	Lower Channel
Sign	Data Frame, made up of Data bits
Length	Start, Stop and Parity bits

CCITT RECOMMENDATIONS

V.21	300 bps, full-duplex, synchronous and asynchronous, 2-point Frequency Shift Keying
V.22	1200 bps with Fallback to 600 bps, full-duplex, synchronous and asynchronous 4-point Frequency Shift Keying
V.22bis	2400 bps with Fallback to 1200 bps, full-duplex, synchronous and asynchronous 16-point Quadratic Amplitude Modulation
V.23	1200/1200 bps in 4-wire operation, 1200/75 bps in 2-wire operation, 600/600 bps in 4-wire operation, 75/1200 bps in 2-wire operation, 75/600 bps in 2-wire operation, 75/75 bps in 2-wire operation, synchronous and asynchronous, Frequency Shift Keying
V.24	List of definitions for interface cabling between Data Terminal Equipment (DTE) and Data Communication Equipment (DCE)
V.25	Automatic Call-Answering Equipment and/or Parallel Dialling Equipment in the public telephone dialling system, using 200 Group interface cabling
V.25bis	Automatic Dialling and/or Call-Answering Equipment in the public telephone dialling system, using 100 Group interface cabling
V.26	2400 bps with Fallback to 1200 bps, 4-wire dedicated line, 4-phase differential modulation
V.26bis	2400 bps with Fallback to 1200 bps, dialling line operation, half-duplex, synchronous, 4-phase differential modulation
V.26ter	2400 bps with Fallback to 1200 bps, dialling and 2-wire dedicated line operation with echo elimination, full-duplex, synchronous, differential phase modulation
V.27	4800 bps with Fallback to 2400 bps, 4-wire dedicated line operation, 8-phase differential modulation, synchronous, half/full-duplex
V.27bis	4800 bps with Fallback to 2400 bps, full or half-duplex in 4-wire, dedicated line operation, 8-phase differential modulation at 4800 bps; 4-phase differential modulation at 2400 bps
V.27ter	4800 bps with Fallback to 2400 bps, dialling line operation, half-duplex; with 8-phase differential modulation at 4800 bps and 4-phase differential modulation at 2400 bps.

V.28	Definition of the electrical characteristics of so-called non-symmetrical polar lines
V.29	9600 bps, dedicated line operation; Fallback to 7200 or 4800 bps. 16-point quadratic amplitude modulation
V.32	9600, 4800 and 2400 bps with Fallback to 4800 bps dialling line or dedicated line operation; synchronous and asynchronous, echo suppression; 16/32-point quadratic amplitude modulation; differential Trellis Coding and/or non-redundant coding, full-duplex
V.42bis	Error Correction and Data Compression Procedure to CCITT

Table 9 Technical Specifications

Parameter	Spezifications
<i>Methods of operation</i>	Synchronous, asynchronous with manual and automatic dialling (AT-commands; V.25bis);
<i>Error Correction and Data Compression</i>	MNP Classes 1–5, 10 or V.42bis
<i>Transmission rates and Modulation procedure</i>	See <i>Chapter 1</i>
<i>Tolerance for deviation from nominal speed</i>	Max.: +1 (+ 2,3), -2,5%
<i>Character length asynchronous</i>	7, 8, 9, 10, 11 Bits (incl. Star and Stop bits)
<i>Pulse adjustment in synchronous mode</i>	Internal: Local oscillator Extern: Pulse loop (Receive pulse = send pulse)
<i>Interface with telephone network</i>	Dialling line: 2-wire, full duplex
<i>Digital interface</i>	Computer interface: V.24 Protokoll with V.28 level
<i>Automatic dialling</i>	Pulse/MFV dialling
<i>Input for automatic dialling</i>	Serial computer interface
<i>Loudspeaker (external)</i>	Software-controlled: 3 volume levels. Further adjustment via potentiometer
<i>Loudspeaker connection</i>	3.5 mm latching jack (mono); impedance $\geq 4 \Omega$
<i>MFV amplitude fluctuation</i>	<1 dB
<i>Tone duration</i>	90 ms
<i>Frequency/key ratio with pulse dialling</i>	10 pulse/sec 39/61% (On/Off)
<i>Guard tone</i>	1800 Hz, or no Guard tone
<i>Power supply</i>	230 V \pm 10% (external power supply)
<i>Low-voltage jack:</i>	
<i>Charging rate</i>	450 mA AC
<i>Power supply</i>	8.5 VAC
<i>Temperature range</i>	0–45 °C
<i>Storage temperature</i>	-25–+70 °C
<i>Air humidity</i>	max. 85% (Rel.)
<i>Dimensions</i>	140 * 85 * 33 mm (L*B*H)
<i>Weight</i>	ca. 250 g without outlet power supply